



The basics of device circuit breakers

Safe system operation in the event of overload
and short circuit

System availability at the highest level

Increasing demand for high quality and efficiency in production is leading to the construction of increasingly complex systems. At the same time, the requirements for safety and availability are increasing because the failure of one machine or major system parts can result in significant costs. Having a well-planned safety concept for the individual circuits and end devices throughout the entire system is a significant contribution toward operational safety. This also includes selection of a sufficiently powerful power supply and suitable protective devices.

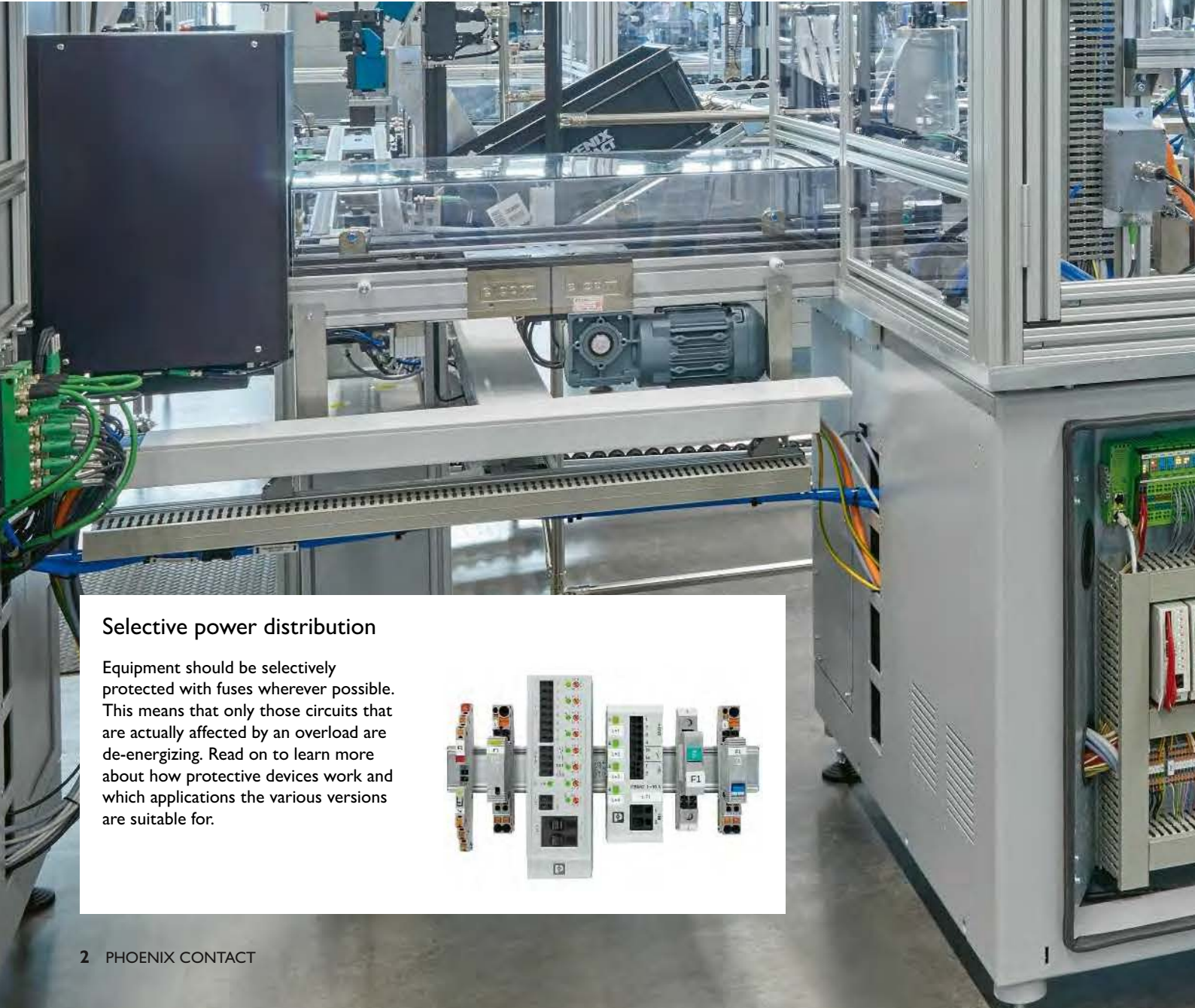

Selective power distribution

Equipment should be selectively protected with fuses wherever possible. This means that only those circuits that are actually affected by an overload are de-energizing. Read on to learn more about how protective devices work and which applications the various versions are suitable for.





Contents

1. Why device circuit breakers?

- 1.1 Benefits and advantages of device circuit breakers
 - 1.2 Differences between miniature circuit breakers and device circuit breakers
 - 1.3 What is a fault?
 - 1.4 System availability
-

2. Differences between the technologies

- 2.1 Thermal circuit breakers
 - 2.2 Thermomagnetic circuit breakers
 - 2.3 Electronic circuit breakers
 - 2.4 Which type of circuit breaker is recommended and when should it be used?
-

3. Extended functions

- 3.1 Remote control and signaling functions
 - 3.2 Nominal currents – Fixed or adjustable
 - 3.3 Adapted backup fuses
 - 3.4 With or without current limiting
 - 3.5 Electrical isolation
-

4. Influencing factors in the application

5. Communication

- 5.1 System transparency
 - 5.2 IO-Link
-

6. Challenges in applications

7. Standards and approvals

- 7.1 European standards
 - 7.2 American standards
 - 7.3 Approvals for shipping
 - 7.4 EU declaration of conformity
 - 7.5 NEC Class 2
-

8. Safe system operation with products from Phoenix Contact

9. Glossary

1 Why device circuit breakers?

The demands being placed on modern machinery and systems have continued to grow in recent years. Supply voltage and fuse protection are a very important part of ensuring system availability. This is because one fault can affect the entire system. The right combination of power supply and circuit breakers can reliably protect machines and systems.

1.1 Benefits and advantages of device circuit breakers

An electrical system consists of many components that must work together in concert. Many loads are supplied by the same power supply in this type of arrangement. This creates dependencies

that are important and critical to system availability. Unscheduled machine downtime is to be avoided at all costs. Therefore it is very important to ensure that, in the event of a fault, any loads and

circuits not involved remain unaffected by the fault. The supply voltage must likewise be maintained in the event of a fault. That is the only way to ensure smooth operation. If an overload or

Power supply main features

Switched-mode power supply units generate a constant voltage and are generally short-circuit proof. Moreover, they are highly efficient. Many switched-mode power supply units offer more than just constant voltage: functions such as static or dynamic Power Boost (Quint Power) for short-term current boosts or SFB pulse for magnetically tripping a miniature circuit breaker. Furthermore, monitoring functions such as DC OK monitoring help raise system availability to a high level. In addition, there are many setting and configuration options available via NFC or directly when ordering. However, if the power supply unit is overloaded and a voltage dip occurs, the connected devices will fail.



short circuit occurs, the best approach is to shut off the fault as soon as possible, depending on how high the current is. This is where device circuit breakers come in.

The elements needed to ensure optimum device protection vary depending on the area of application and availability requirements. This is why different types of device circuit breakers that work with different technologies have been developed over time. These types include electronic, thermomagnetic and thermal device circuit breakers. They differ from each other in how they are tripped, their shutdown behavior, and their tripping time. Characteristic curves are used to clearly illustrate the shutdown characteristics of the various device circuit breakers. Furthermore, selection also depends on what precisely is needed in terms of protection and system availability.

Controller standard IEC/EN 61131-2

This standard describes the equipment requirements and testing for programmable logic controllers. There are two important points to note here to ensure system availability:

- A controller in a non-battery-powered system must be able to withstand a voltage dip of up to 10 ms without any effect. This results in a time window within which a shutdown must occur if there is a threat of a longer voltage dip.
- The guaranteed operating voltage range must fall within the range of 19.2-30 V DC. The controller may fluctuate above or below the specification, which can lead to malfunctions.

However, controllers are generally able to function with lower voltages. The standard can only be used as a baseline, however, which makes the indicated voltage range significant at a fundamental level.

1.2 Differences between miniature circuit breakers and device circuit breakers

Miniature circuit breakers (MCBs)

Miniature circuit breakers were designed and developed first and foremost to provide cable protection in a building. They are covered under the standard IEC/EN 60898 (Electrical accessories – Circuit-breakers for overcurrent protection for household and similar installations). The current drawn by the load is not known at this point. Therefore, the wiring is designed such that it can continuously carry the nominal current of the protective device. At the same time, a certain amount of inertia is desired, because the cable must be protected and the tripping should not be too fast. For a long time, lower current values were not used, as these are not necessary for the building installation. Furthermore, miniature

circuit breakers are characterized by their high short-circuit shutoff capacity, which is necessary for operation on the grid. The electric arc that occurs at shutoff is high in energy and needs to be interrupted during shutoff. This is the only way to ensure a safe shutoff.

Device circuit breakers

Device circuit breakers are described in IEC/EN 60934. They are not just used for cable protection, but first and foremost for device protection. For this reason, their nominal currents start at less than 1 A and they are subdivided into small current increments. This makes it possible to adapt the protection to the corresponding device as precisely as possible. A variety of characteristic curves that have been specially developed

and established for DC voltage also assist in this.

Since device circuit breakers do not depend directly on the mains, no quenching plates are required, as is the case with miniature circuit breakers. They are therefore significantly more compact, saving space in the control cabinet.

Problems associated with MCB-based protection

MCBs were designed for different applications than device circuit breakers. Therefore, they need a very high tripping current:

An MCB shutoff is divided into two parts: a thermal and a magnetic shutoff. Thermal shutoff takes place in the lower seconds to minutes range, whereas

the magnetic shutoff occurs in the event of a short circuit and ideally falls in the 3 to 5 ms range. Depending on the characteristic curve in use, up to 15 times the normal current needs to be flowing for a rapid short-circuit cutoff. If this current is not available, the entire system can be affected. The required current may be limited downstream of a switched-mode power supply unit or if the line impedance is too high. This means that the required higher tripping current may not be reached, causing the system voltage to dip. The result is that parallel loads fail.

MCBs are designed for the AC grid (without power limitation): miniature circuit breakers were developed for installation in buildings, and that is precisely what the currents and characteristic curves are designed for. Therefore, there are no nominal current values in the lower amp range, or a slow characteristic curve needs to be selected in order to reach the right nominal current. In principle, the characteristic curves were initially established for use only with AC voltages. If these types of fuses are used with DC voltage, a correction factor of around 1.4 must be taken into consideration in the

short-circuit tripping range. Tripping therefore occurs even later, often not until a current 15 times the nominal current has been reached. Thus, in the case of a C6 quick-break cutout, a current of up to 90 A must be reckoned with for serious events. If this tripping current is not available downstream of a switched-mode power supply unit, the entire system will experience a voltage dip. The same is true for a cable that is too long. It can create a situation where the current is limited, thus preventing prompt tripping, which in turn can also lead to a voltage dip in this case.

1.3 What is a fault?

Overload currents and short-circuit currents are usually unexpected. They cause malfunctions and interrupt the operation of a system. Production downtimes and repair costs are often the unpleasant result.

Effects of this type can be minimized by protecting individual devices separately or by logically organizing the devices in groups. Since different loads also have different nominal currents (Fig. 1), it makes sense to implement separate protection for each individual circuit.

Ideally, the nominal current selected will be close to the nominal current for the load. In this way, end devices are optimally protected against damage or destruction. System parts that are not in the affected circuit can continue to operate without interruption, provided the overall process allows it. This ensures high system availability.

Voltage dip

Machines and systems for the most part operate with different supply

voltages. These largely range between 12 and 48 V DC. For the primary applications, 24 V DC has been the control voltage generally used for many years now. Synchronized power supply units are standard equipment in most industries for control voltages. This voltage consistently delivers high efficiency. In addition, the output current is limited. The voltage can also be maintained over great distances using DC/DC converters.

Like fuses and circuit breakers, power supplies also come with a variety of characteristic curves, allowing them to meet different system availability demands. Many power supply units use the U/I characteristic curve, for example (Fig. 2). The voltage is constant, the current is variable. If the current exceeds the nominal range, or if an overload leads to a voltage dip, the connected loads fail.

If the PLC (programmable logic controller) fails, the only way to find and eliminate the error is through an enormously painstaking search.



Fig. 1: Typical nominal currents of electrical loads

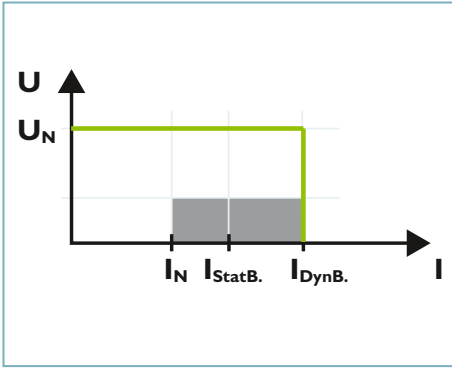

Fig. 2: Power Supply U/I characteristic curve

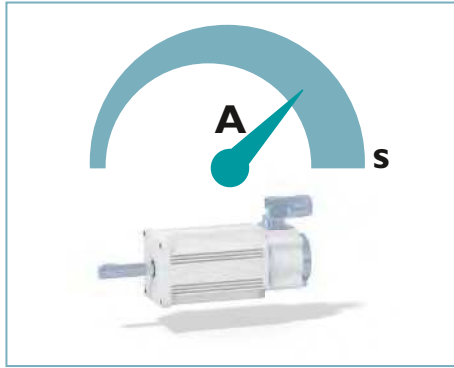

Fig. 3: Shutdown of overload currents in the seconds range

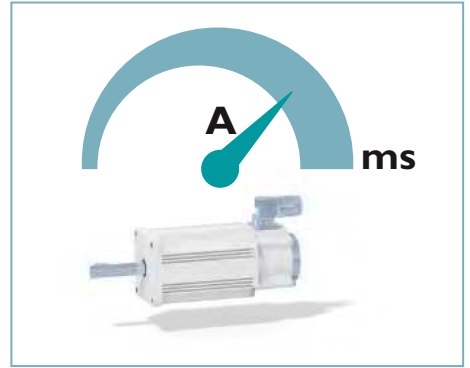

Fig. 4: Shutdown of short-circuit currents in the milliseconds range

Overload

Overload currents occur if end devices unexpectedly require a higher current than the intended rated current. Such situations can arise, for example, due to a blocked drive. Temporary starting currents from machines are also considered to be overload currents. The occurrence of these can be calculated in principle, but nonetheless can vary depending upon the machine load at startup time. When selecting suitable fuses or circuit breakers for these types of circuits, these conditions must

be taken into account. Safe shutdown in the event of an overload should occur in the seconds range (Fig. 3).

Short circuit

Damage to the insulation between conductors which carry operating voltage, e.g. a damaged load feed, can cause short circuits. In the past, typical protective devices for shutting down short-circuit currents included fuses or miniature circuit breakers with a variety of tripping mechanisms. Since then, electronic protective devices have come

into general use. Short-circuit currents need to be safely shut off within a few milliseconds in order to prevent any effect on the remaining loads in the system (Fig. 4). This is because a short circuit generally leads to a voltage dip, which can also cause other unaffected circuits and loads to fail.

1.4 System availability

System availability reflects the actual versus scheduled production time for a machine or system expressed as a percentage. System downtime or failure has a direct negative impact on availability. Production processes are being optimized more and more because every second that can be saved counts. All of the steps in a production process repeat cyclically. Ideally, this means that any optimization adds up over time.

It is especially important to be able to permanently monitor system status in order to keep an eye on all of the relevant indicators. If a fault can be detected prior to a failure, a timely response can be made – planned maintenance saves time and money.

Having the right protection in the system also plays an important role in maximizing system availability. If a fault is present, whether it is an overload or a short circuit, it must be detected quickly and shutdown must occur within a few milliseconds if possible. Devices connected in parallel are shut down along with it. For this reason, it is important to structure the protection as finely as possible in order to avoid compromising parallel loads. This is also referred to as parallel selectivity.

Selectivity

Selectivity can be subdivided into absolute and conditional selectivity. The safest form is absolute selectivity. This is the only way to ensure that the tripping ranges of two safety devices

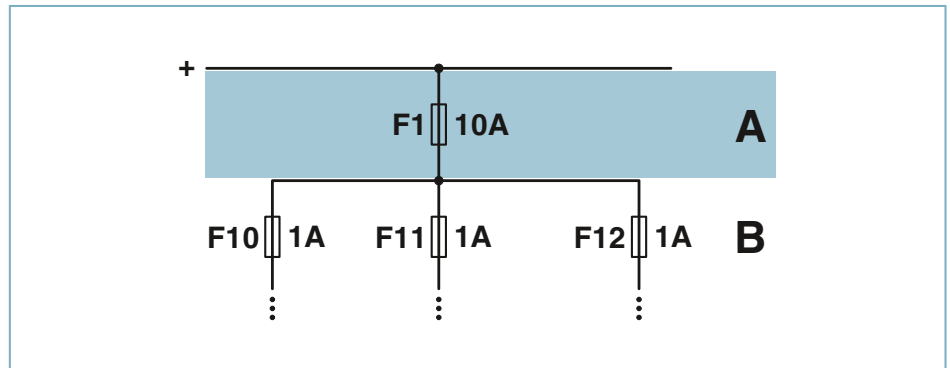

Fig. 5: A is the backup fuse and B is the safety equipment for the individual circuits

do not overlap in the overall progression and that only the immediately upstream fuse trips in the event of a fault. With conditional selectivity, there are overlaps in the characteristic curves. This can lead to a situation where the safety equipment and the upstream backup fuse trip, or even a situation where only the upstream backup fuse trips (Fig. 5).

Parallel selectivity

Parallel selectivity describes how parallel circuits affect each other. If a fault is present, it must be shut down. Other system parts, on the other hand, should continue to run undisturbed, provided the process permits. Since a voltage dip involves all parallel circuits, the shutoff must take place in an appropriately selective manner. If parallel load circuits are affected, there is no selectivity.

Serial selectivity

Selectivity can also be serial. However, this requirement arises primarily from the fuse domain or from building engineering. In this case, the superordinate fuse must

have a value that is high enough that only the next higher fuse in the current path is tripped. This results in better fault containment and increases the line protection. The superordinate value must be at least 1.6 times the nominal. As a general rule, the fuse is designed two fuse steps higher, since the standard values for a fuse will then meet the factor of 1.6. What is important here is that the characteristic curves are mutually selective.

2 Differences between the technologies

The demands placed on optimum device protection vary depending on where it is deployed and how it is used. Device circuit breakers therefore work with a wide range of technologies: electronic, thermal, and thermomagnetic.

The differences are in the tripping technology and shutdown behavior. Characteristic curves clearly illustrate the switch-off characteristics of the various device circuit breakers.

2.1 Thermal device circuit breakers

Thermal device circuit breakers provide optimum protection against overload for inductive and resistive loads in power distribution systems, control cabinet engineering, and systems manufacturing. They are resistant to high starting currents such as those that occur when starting a motor or switching on a transformer. They are also used for protecting circuits in battery and onboard systems. Compared to other protection technologies, however, thermal circuit breakers do not offer rapid protection from short circuits.

Function description

The tripping element of thermal device circuit breakers is bimetallic. It may also be a combination of bimetal and an electrical heating element. The bimetal consists of steel and zinc, which is formed by heat. When a predefined heat level is reached as a result of an excessively high current in the heating element, the thermal bimetal trips the shutdown mechanism.

This thermal tripping element makes the thermal protection more susceptible to higher ambient temperatures. Thermal

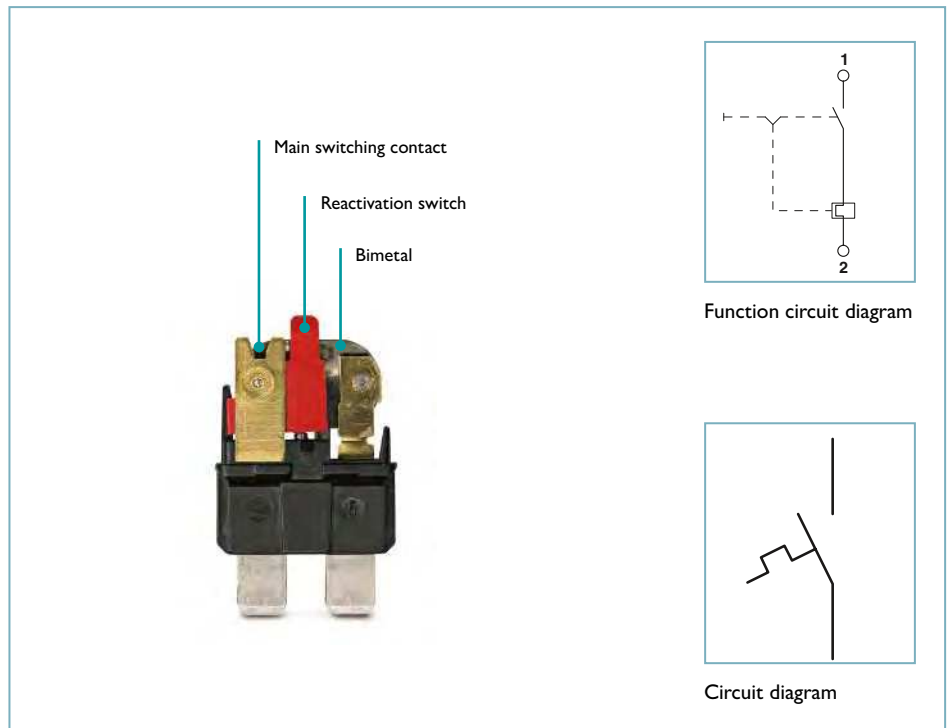

Fig. 6: Structure and functional description of thermal circuit breakers

device circuit breakers represent a simple, cost-effective solution for applications which do not necessarily require fast and precise shutdown (Fig. 6 and 7).

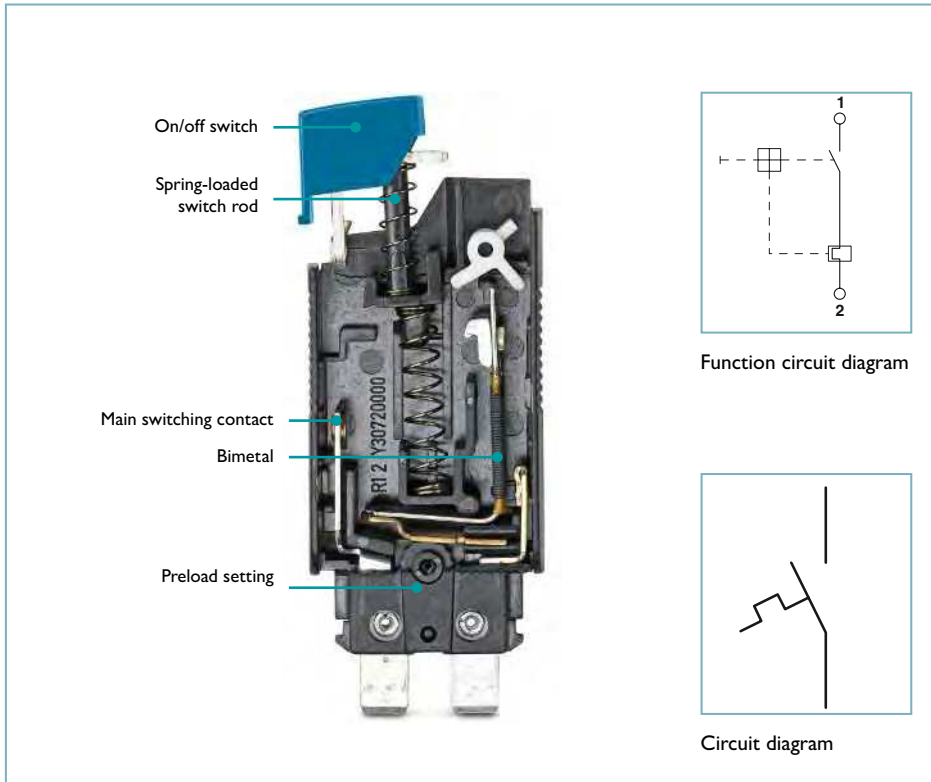

Fig. 7: Structure and functional description of thermal circuit breakers

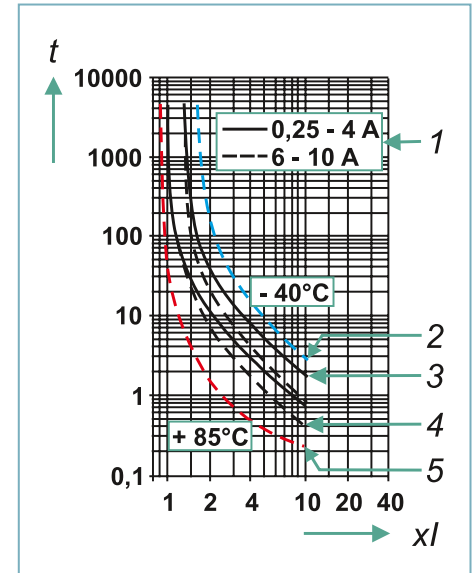

Fig. 8: Typical tripping characteristics for thermal circuit breakers:
 t Switch time (in seconds)
 xI Multiple of the nominal current/tripping factor
 1 Current ranges of the characteristic field
 2 Tripping characteristics of the lower temperature range (blue)
 3 Tripping characteristics group 1
 4 Tripping characteristics group 2
 5 Tripping characteristics of the upper temperature range (red)

Tripping characteristics

The tripping time of thermal device circuit breakers depends on the overload current that is flowing and the ambient temperature. The characteristic curves show that the tripping time is reached faster as the overload increases. With smaller overload currents, it therefore takes longer for the connected load

to be disconnected from the power supply (Fig. 8). For circuit breakers with different nominal currents, but with the same tripping characteristics, the tripping can also be presented in characteristic curve fields (Fig. 9). Of course, thermal device circuit breakers respond to the effects of heat. The ambient temperature can also affect the tripping time. The

circuit breaker trips more easily at a high ambient temperature and more slowly at a low ambient temperature. This behavior is indicated by additional characteristic curves with corresponding information.

2.2 Thermomagnetic circuit breakers

Thermomagnetic device circuit breakers are used among other things in information and communication technology as well as process control. Thanks to a variety of versions with different tripping characteristics, circuit breakers are ideally suited for protecting programmable logic controllers, valves, motors, and frequency converters. The reactivation and immediate

remote signaling of the operating state ensure high availability. The different characteristic curves for this protection technology can even start critical loads while at the same time providing secure protection in nominal operation.

Function description

Thermomagnetic circuit breakers are equipped with two trip mechanisms.

The temperature-dependent part of the mechanism consists of a bimetal with a heating coil (Fig. 10). Currents that exceed the nominal current of the protective device generate heat in the heating coil. This causes the bimetal to bend and act on the switching mechanism. When the limit value is reached, the protective device shuts down. The devices respond to overload

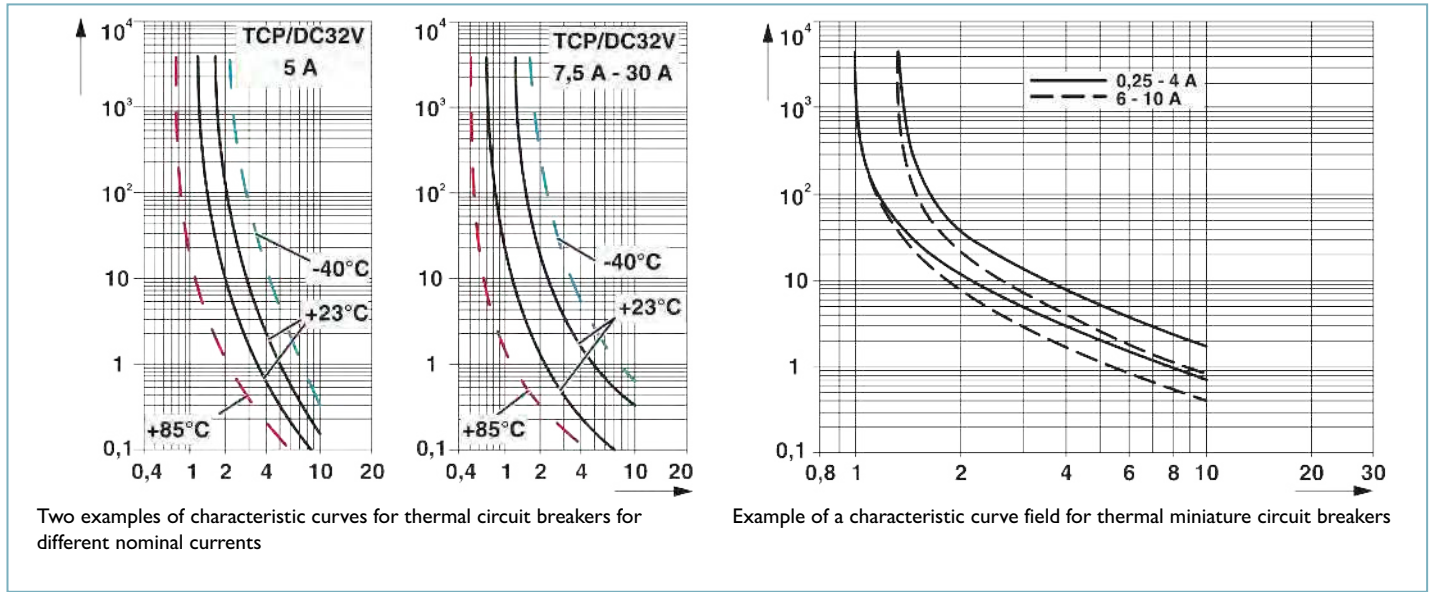

Fig. 9: Key characteristic curves of thermal circuit breakers at a glance

currents with a delay. The thermal part of this circuit breaker technology also makes it more susceptible to higher ambient temperatures.

The magnetic trip mechanism is designed with a solenoid coil and a

plunger or pivoted armature. Currents that exceed the nominal current of the protective device create a magnetic field in the coil. The current strengthens the magnetic field and attracts the armature. When the preset limit value is reached,

the armature actuates the trip mechanism and shuts down the protective device. These devices respond to short-circuit currents and excessive overload currents within 3 to 5 milliseconds.

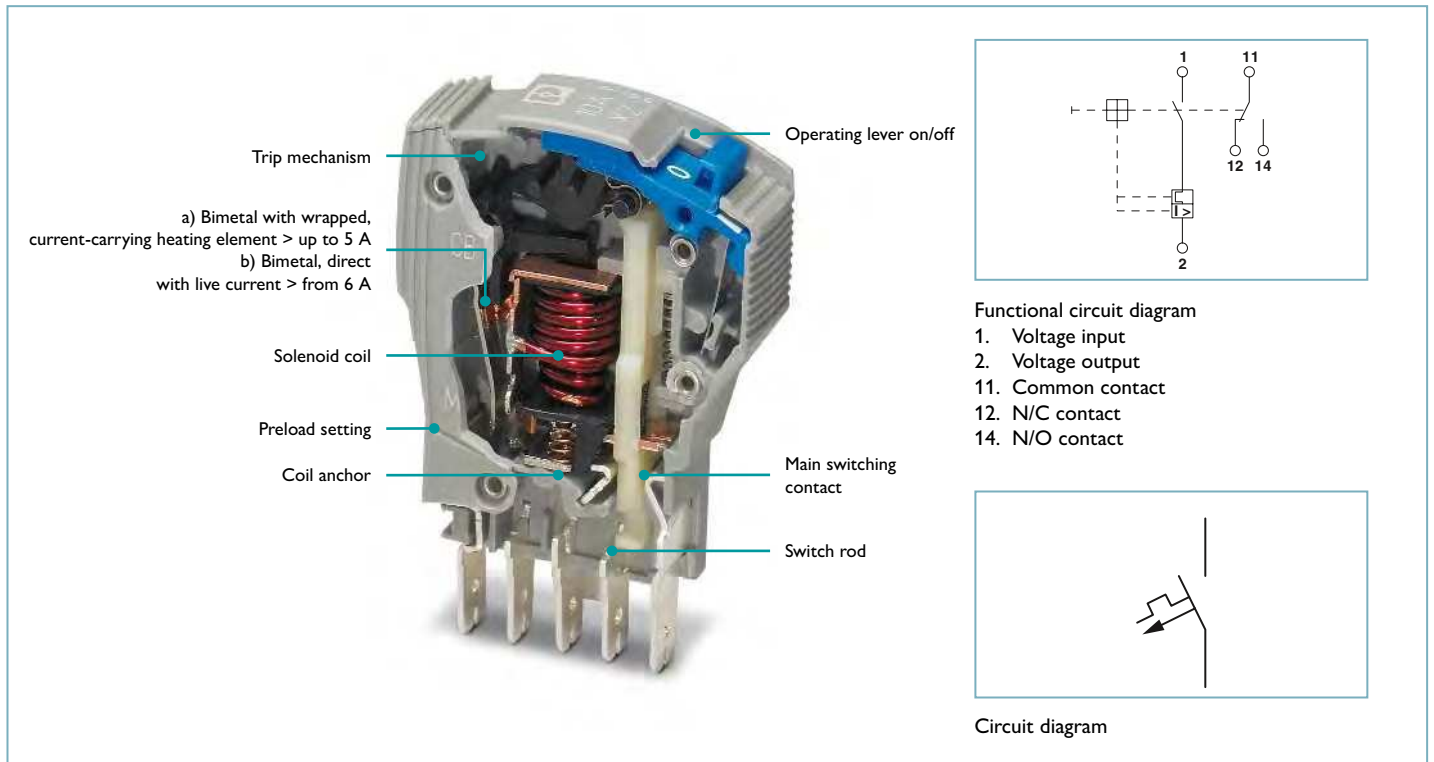

Fig. 10: Structure and functional description of thermomagnetic circuit breakers

Tripping characteristics

Thermomagnetic device circuit breakers are available with different characteristic curves. This allows them to meet the wide range of requirements that result from different application cases. The characteristic curve (Fig. 11) indicates that the thermal trip [a] responds considerably later than the magnetic trip [b]. This can be explained by the required heating time of the temperature-dependent trip mechanism. However, even currents that are slightly higher than the nominal current are identified as overload currents and shut down. Magnetic tripping responds very quickly to rapidly rising currents that exceed the nominal current. This is particularly advantageous for detecting and switching off short-circuit currents. Alternating currents trip faster than DC currents at the same nominal value. This is depicted by the blue area in the curve. This behavior is generally applicable to all characteristic curves. Nevertheless, it is only used for circuit breakers with the M1 characteristic curve. Circuit breakers with the SFB or F1 characteristic curve also trip so fast with direct current that they would respond overly sensitively during operation with alternating current.

SFB characteristic curve

Circuit breakers with the SFB tripping characteristic (Fig. 12) offer maximum overcurrent protection, even in extensive systems with long cable paths. SFB stands for Selective Fuse Breaking, i.e., selective shutdown. Protective devices with this characteristic curve prevent an unnecessarily early switch-off

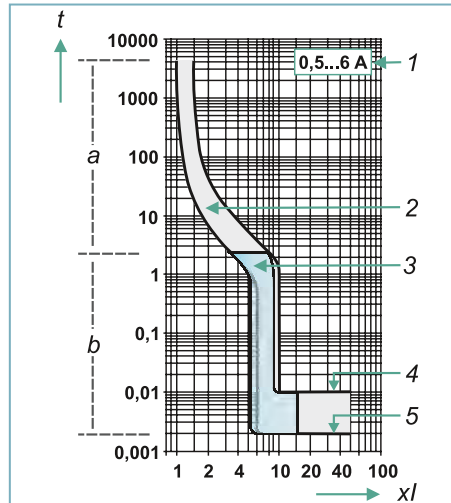

Fig. 11: Typical tripping characteristics for thermomagnetic circuit breakers
 a Operating range for thermal tripping
 b Operating range for magnetic tripping
 t Switching time (in seconds)
 xI Multiple of the nominal current/tripping factor
 1 Current range for which the characteristic curve applies
 2 DC tripping range (gray)
 3 AC tripping range (blue)
 4 Tripping maximum
 5 Tripping minimum

in the event of brief current increases and starting currents during operation. They simultaneously prevent unnecessarily long, persistent overload currents, which may lead to the hazardous generation of heat in operating equipment.

M1 characteristic curve

Circuit breakers with the M1 characteristic curve (Fig. 13) trip later than those with SFB or F1 characteristic curves. They withstand starting currents for somewhat longer periods but consciously respond less swiftly to fault situations. In comparison to the direct current characteristic curve, the alternating current characteristic

SFB technology

QUINT power supplies from Phoenix Contact feature Selective Fuse Breaking Technology, also known as SFB. These power supplies can supply six times the nominal current for a few milliseconds. This enables them to provide the necessary current reserve for safe tripping of the protective devices.



curve is dragged forward on the axis of the nominal current multiple. Even at a lower multiple of the nominal current, alternating currents cause the circuit breaker to trip.

F1 characteristic curve

Circuit breakers with the F1 characteristic curve (Fig. 14) trip quickly. They react very quickly to overload situations. However, this can lead to unnecessary shutdowns during operation. This means they offer optimal protection for sensitive loads with very low starting current and thus provide protection over great distances. End devices, which can be damaged by temporary overloads and slightly increased operating current, are also protected by these circuit breakers.

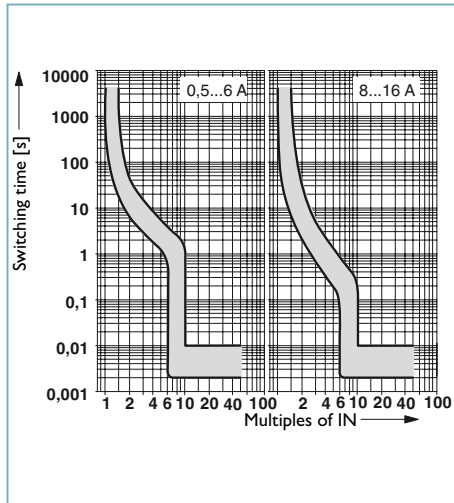

Fig. 12: SFB characteristic curve

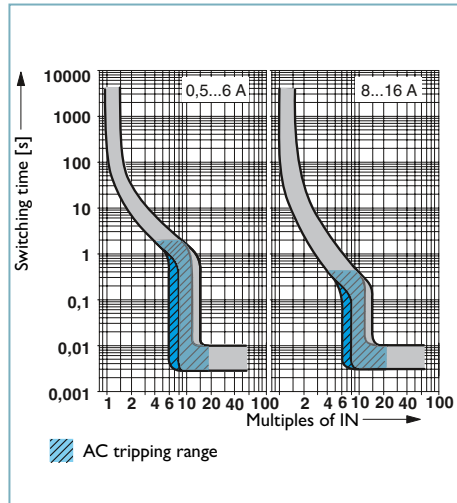

Fig. 13: M1 characteristic curve

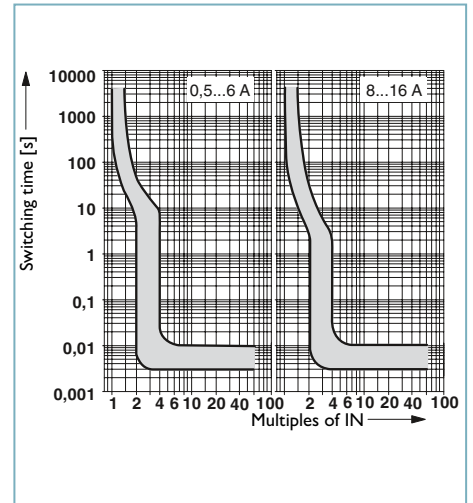

Fig. 14: F1 characteristic curve

2.3 Electronic circuit breakers

Electronic circuit breakers are generally used in conjunction with 24 V DC switched-mode power supply units. They are frequently used in machine and ship building, systems manufacturing, and automation technology. A combination of current analysis and rapid tripping in the event of a fault prevents the danger of a switched-mode power supply unit overload. The output voltage remains in

place at the switched-mode power supply unit and all other circuits can continue to operate. These circuit breakers are ideal for protecting things like relays, programmable controllers, motors, sensors and actuators, and valves. Combining electronic circuit breakers with a synchronized power supply can increase the availability of systems and machines.

Function description

The heart of an electronic circuit breaker is its semiconductor electronics (Fig. 15), which nowadays is generally assisted by intelligent software. The software differentiates between operating currents and damaging currents and transmits commands to the electronic system extremely rapidly. This is because it has to ensure that faults are detected and shut down as quickly as possible while not shutting off an inrush current or normal operating current.

The fault detection process passes through the following steps:

- **Measurement:** All electrical variables are measured continuously in order to monitor the ongoing situation.
- **Analysis:** The measured values are analyzed to determine whether a fault has occurred.
- **Classification:** The currents are evaluated and classified.
- **Protect and switch:** Depending on the class of the analyzed current, the load is started or shut down. The rest of the system remains in operation and unaffected.
- **Signaling:** The operating states of all circuits are transmitted continuously to the superordinate

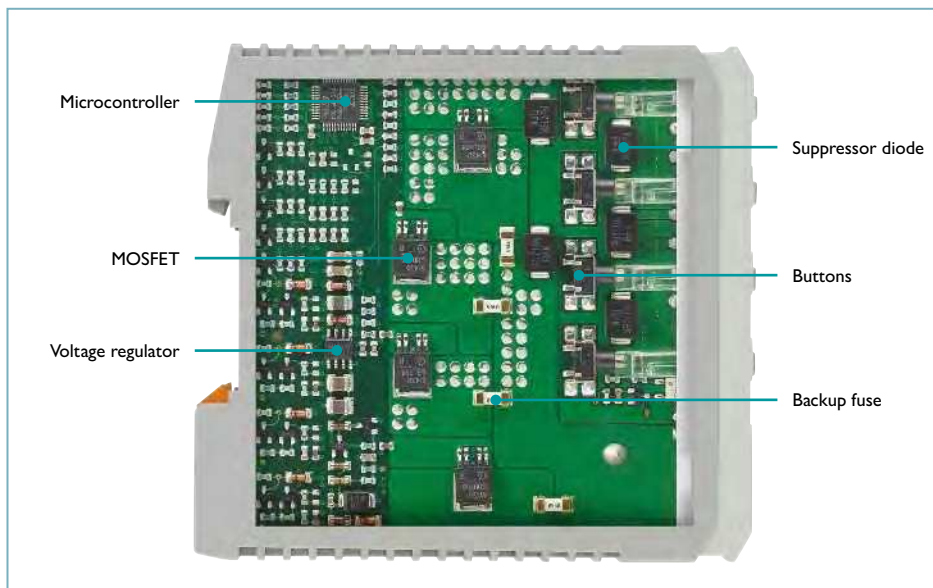

Fig. 15: Structure of a multichannel electronic circuit breaker

system controller. If an event occurs, it is detected immediately and reported.

This approach reduces the period of any voltage dip to a minimum. Despite the event, the system voltage remains stable. In the event of overload current or a short circuit, the devices are promptly switched off.

Electronic circuit breakers are in some cases equipped with active current limiting. This function limits the short circuit and overload currents, depending on the product range, to a value of 1.25 to 2 times the nominal current.

This protects the power supply against currents that are too high and prevents the output voltage from dropping at the switched-mode power supply unit.

Another benefit of this electronic technology is the ability to virtually completely plan out the connected load of any DC power supply. In addition, longer cable paths between the power supply and load are possible without negatively impacting the shutdown behavior.

Tripping characteristics and dynamics

Thanks to intelligent current analysis, modern electronic circuit breakers can differentiate between many different operating and failure scenarios. The result is a dynamic in the characteristic curve. This means that any fault-related shutdown is not dependent solely on current and time. The load and power supply are detected, optimizing the startup process. In this way, the operation of the electronic protection is illustrated in a dynamic characteristic curve. Similar to traditional fuses, this is also done by defining an overload and short-circuit range.

Some electronic circuit breakers have different characteristic curves. The purpose of these differences is first and foremost to offer the user familiar selection options. However, it is not necessary to differentiate

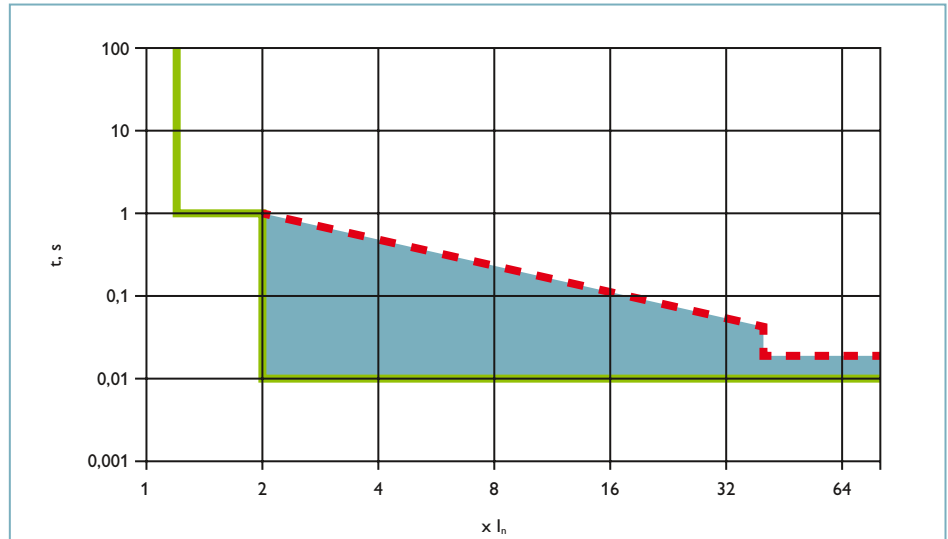

Fig. 16: Short-circuit behavior and dynamic overload detection range

among different characteristic curves. As opposed to thermal or thermomagnetic fuses, the electronics in modern electronic circuit breakers react dynamically.

Figure 16 shows the various ranges:

1. Short circuit behavior (green line): If a short circuit is detected, the fault is immediately shut down. To prevent any negative impact on the loads, this has to happen without a time delay. Particularly with a PLC, a shutdown must occur within 10 ms (see also controller standard, p. 5).
2. Dynamic overload detection range (blue area): Depending on the height and course of the flowing current, the intelligent detection also ensures a shutdown in the case of an overload. This process permits the overcurrent to persist for different lengths of time, depending on its progression and the stability of the supply voltage. The overload is shut down before a dangerous condition arises. Here also, the dynamics associated with electronic circuit breakers provide a critical advantage. If a fault is detected, it is shut down promptly, keeping the remaining supply in mind. Loads can be detected in this way and can be started even when high starting currents are present.

When it comes to burn-through fuses and thermomagnetic circuit breakers, the different characteristic curves are known, such as fast-acting, medium blow, or slow blow. A modern electronic protective device with intelligent short-circuit detection and dynamic overload behavior is replacing the wide range of characteristics mentioned above.

2.4 Which type of circuit breaker is recommended and when should it be used?

Device circuit breakers are selected based on the nominal voltage, nominal current, and, if required, the starting current of an end device. In addition, the shutdown behavior of the device circuit breaker must correspond to the expected fault situations. Fault situations are divided into short circuit and overload.

A thermal device circuit breaker provides pure overload protection. However, it is not equipped with a protective mechanism that can quickly and reliably protect the application from short circuits. This means that increased tripping times occur in the event of short circuits.

Thermomagnetic circuit breakers are also significantly better suited for safely



protecting a load from short circuits. They offer a combination of medium-blow overload protection and fast-acting and reliable short-circuit protection.

Even very high starting currents are no problem for most thermomagnetic characteristic curves.

Electronic circuit breakers are significantly more accurate. Circuit breakers with an electronic characteristic curve are used to create fast-acting overload and short circuit protection. They are used upstream from particularly sensitive loads and protect not only against overly long, but also against overly high loading. Electronic circuit breakers are therefore not just especially well suited

for protecting systems and machines, but also often provide comprehensive diagnostic options. Remote maintenance can be designed to be significantly more comprehensive.

Moreover, thanks to its extended remote signaling and control options, this type of circuit breaker can be used in some cases in hard-to-reach applications.

Recommended selection depending on shutdown behavior and fault situation		
	Tripping time in the case of overload	Tripping time in the event of a short circuit
Thermal circuit breakers		
Thermomagnetic circuit breakers		
Electronic circuit breakers		

Shutdown behavior: ■ Unsuitable ■ Adequate ■ Ideal

3 Extended functions

The choice of which device circuit breaker is best suited for a given application is based not just on the technology and the associated shutdown behavior. In addition to features such as with or without current-limiting technology or the option to adjust the nominal current, the type of auxiliary contact or signaling and control signals also plays a role.

3.1 Remote control and signaling functions

Reset or control input

A reset input can be used to remotely switch a tripped device circuit breaker back on. A control input can be used not just to switch the device circuit breaker back on, but also to switch it on and off during normal operation. This type of operation is similar to that of a relay that is actuated.

Status output

A status output is used to output a voltage level at a terminal point that can be sent to a PLC's digital input, for example. Normally, a "HIGH" signal is output when everything is OK, i.e., is operational, and a "LOW" signal is emitted when the device circuit breaker has been tripped by a fault. The advantage of this signal level definition is that it also covers detection of a wire break in the signaling connection to the PLC.

To use fewer PLC inputs, the signal levels must be exactly the opposite of the ones described above. This can be done by grouping the individual status output signals of multiple single-channel device circuit breakers into one group signal. In that case, you need products with an inverted status output. With these types of products, a "LOW" signal is output

when everything is OK, i.e., operational. A "HIGH" signal is output when one or more device circuit breakers have tripped due to a fault. However, this means that wire break detection for the signaling connection is no longer an option with these devices.

N/O or N/C signal contact

These types of signal contacts involve 2-position potential-free status contacts that can be individually wired and interconnected.

An N/O contact is a normally open contact. This means that the contact is closed when everything is okay. If the device circuit breaker trips due to a fault, the contact opens. Wiring all of the contacts in series makes it easy to construct a simple group signaling arrangement for a group of device circuit breakers. In this case, one end of the series connection must be connected to a +24 V source, while the other must be connected to a digital PLC input.

An N/C contact is a normally closed contact. This means that the contact is open when everything is okay. If the device circuit breaker trips due to a fault, the contact closes (Fig. 17).

Individual signaling or group signaling

Multichannel device circuit breakers are generally equipped with group signaling in the form of a potential-free N/O contact. Single-channel device circuit breakers for the most part are also equipped with one N/O contact for single channel signaling. However, in the case of a group of individual devices, they can also be connected in series and in this way grouped into a group signaling arrangement. This can in some cases save several digital inputs on a PLC as opposed to single-channel signaling.

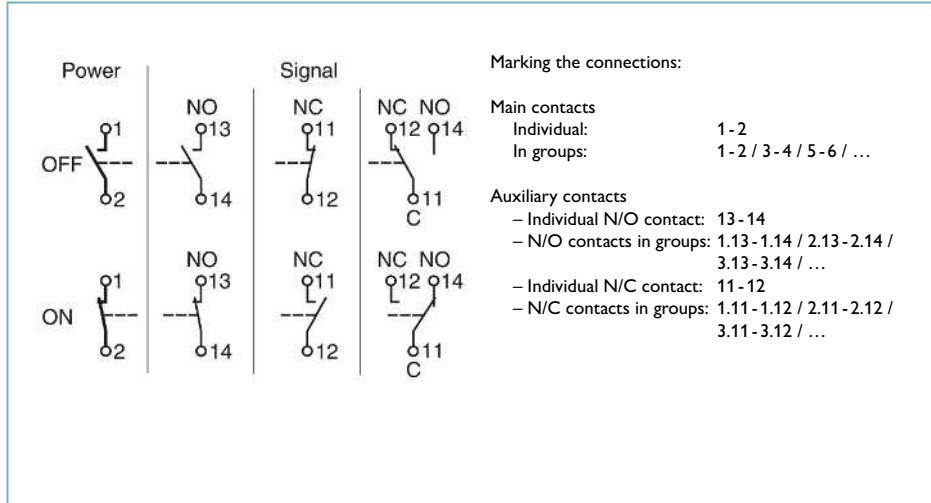

Fig. 17: Setting for auxiliary contacts based on switching state of the main contact

- Power main contact
- Signal auxiliary contacts
- NO normally open (N/O) contact
- NC normally closed (N/C) contact
- C common changeover foot contact (common)

3.2 Nominal currents – Fixed or adjustable

The correct nominal current for a device circuit breaker can be determined either at time of purchase or left open up until the time it is installed in the application. This means that the decision involves choosing either a product with a fixed nominal current or one with an adjustable nominal current range. The

latter option allows you to separately adjust to the nominal current that is right for the application, e.g., using a potentiometer, step switch, or one-button operation. One major advantage of this adjustability is that you still have the freedom to respond to adjustments and revisions in the system up until

the devices are installed. This option is available with fixed-value devices only in cases where the decision is made to use pluggable versions. In that case, the nominal current remains unspecified until the choice of which device circuit breaker connector to use is made.

3.3 Adapted backup fuses

In electronic circuit breakers, a backup fuse is built in to serve as a fail-safe element. This is done to cover the rare instance of a technical failure in the main switching element (MOSFET) to protect it from thermal destruction.

A fuse is considered to be an electrical device. That means it must also be protected. This can be done via an external fuse, but is not necessary thanks to the fuse already incorporated in the electronic circuit breaker.

devices with a low maximum nominal current are also available, so as to better protect sensors or other sensitive loads.

A fail-safe element is required under the American UL standards. An electronic

The size of the backup fuse should match the application, for which reason

3.4 With or without current limiting

Depending on the application, the following decisions have to be made: Current-limiting technology has the benefit that it never allows more current than the amount up to the predefined limit to flow in the load circuit. The limit is generally between 1.25 to 2.0 times the nominal current. This also prevents the power supply from being too severely overloaded. To the power supply, even a hard short circuit appears only as a slight overload. There is also no need to lay

over-dimensioned cables. In some cases, however, current-limiting technology allows too little current at startup time. However, that is exactly what is needed for a trouble-free load startup, e.g., in order to create the motor starting torque.

Device circuit breakers without current-limiting technology ensure that the full amount of current is allowed through in the load direction at startup

time. This allows even heavier loads to start up faster, e.g., motors with high starting torque or capacitive loads. Intelligent current analysis procedures are used for this that can differentiate between a true hard short circuit and high inrush currents. This ensures a safe shutdown before critical system operation conditions arise.

3.5 Electrical isolation

In many industries, such as the process industry, actual electrical isolation is required. This is used to ensure that there is no longer any physical connection to the power supply in cases such as shunting for maintenance purposes. The current path is broken via complete electrical isolation in the event of a fault.

This requirement is not a challenge for thermal and thermomagnetic device circuit breakers. Due to its working

principle, when a MOSFET is used as the switching element in an electronic circuit breaker, it is unable to do this. At the moment of actuation, it is very high-impedance and cuts the current flow off almost completely without truly opening the contact.

A combination of relays and MOSFET can also provide a robust and long-lasting solution for achieving electrical isolation. The load current is routed over the MOSFET during

the shutdown and restart process. This protects the contacts of the electrical isolation element (relay) from contact burn-through or fusing. In the switched-on operating state, however, the load current is routed virtually loss-free over the relay.

4 Influencing factors in the application

Some applications often require very long cable paths, which can significantly impair system operation. In the event of a fault, the required tripping current may be limited by overly high line impedance. This results in a shutdown occurring too late. Not infrequently, this can lead to a voltage dip and system downtime. The maximum cable lengths that can be used between the power supply and the end device depend on a range of factors:

- Type of power supply (characteristic curve)
- Power supply maximum current (Power Boost, SFB Technology, etc.)
- Internal resistance or voltage drop for the protective device being used
- Cable resistance (material, cross section, length)
- Theoretical contact resistance at terminal points
- Effects of temperature

The factors that can be directly influenced include the type, the cross section, and the length of the cable. The selected cabling path should be as short as possible, since the cable resistance fundamentally counteracts any short-circuit current. In the case of miniature circuit breakers, a multiple of the nominal current is required to ensure safe and quick shutdown and should be, depending on the characteristic used, up to 15 times the nominal current. With such a high current demand in the event of a fault, the cable resistance very quickly acts as a limiting factor that causes the short-circuit current not to be detected as such. The result is that shutdown occurs too late and entails a voltage dip for all loads on the same voltage source (Fig. 18).

For that reason, it is of the utmost importance to find the right characteristic curve. It should of course allow the load to start, but also trip promptly in the event of a fault. In this

Maximum short-circuit currents (24 V DC)						
Distance between power supply/load	Conductor cross section					
	0.34 mm ²	0.5 mm ²	0.75 mm ²	1.0 mm ²	1.5 mm ²	2.5 mm ²
2 m	119 A	175 A	263 A	351 A	526 A	877 A
4 m	60 A	88 A	132 A	175 A	263 A	439 A
6 m	40 A	58 A	88 A	117 A	175 A	292 A
10 m	24 A	35 A	53 A	70 A	105 A	175 A
20 m	12 A	18 A	26 A	35 A	53 A	88 A
30 m	8 A	12 A	18 A	23 A	35 A	58 A
40 m	6 A	9 A	13 A	18 A	26 A	44 A
50 m	5 A	7 A	11 A	14 A	21 A	35 A

Fig. 18: The table shows the maximum current that can flow through a given copper conductor. This clearly shows how the current is greatly attenuated by the cable resistance. This means that a short circuit may not be able to be shut down promptly under some circumstances.

case, a characteristic curve like the SFB characteristic, which falls between a B and C characteristic, can often prove useful. However, the power supply should have the required tripping current in reserve. This also serves to ensure

safe operation. If the cable cannot be run in shorter lengths or larger cross sections, an additional electronic circuit breaker can generally be used as a protective device. This is because an electronic circuit breaker responds to

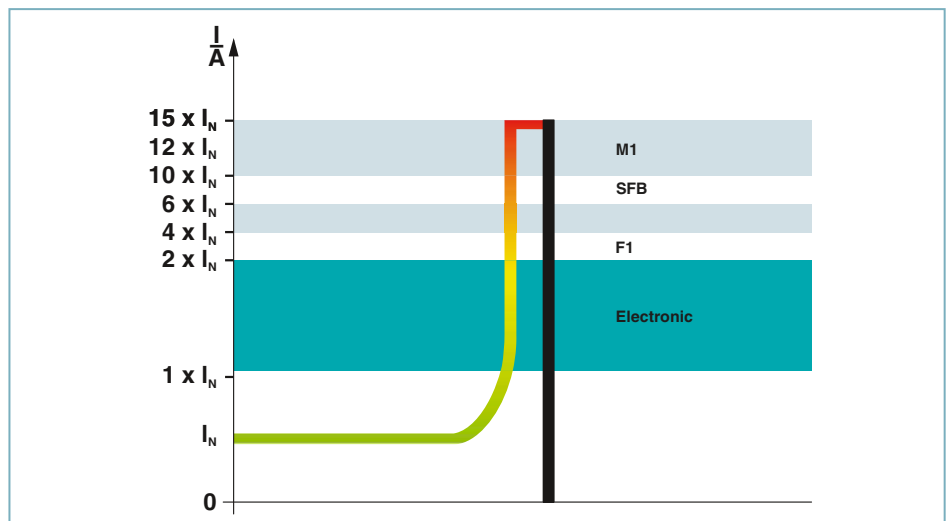

Fig. 19: The tripping current for electronic circuit breakers is significantly lower than for thermomagnetic circuit breakers.

currents near the nominal current. If the flowing current is detected as a fault, the shutdown occurs quickly. The cable resistance that would have acted to excessively limit the tripping current is suddenly no longer a factor (Fig. 19).

In the case of electronic overcurrent protection, currents and voltages are measured and analyzed, fault currents are detected and shut down accordingly. This places the required fault current in the range of 1.2 to 2.0 times the nominal current, and not up to 15 times, as is the case with mechanical circuit breakers. This enables much more precise protection. However, in the case of long cables, the voltage drop is much more significant, since it is of little benefit that the current arrives at the load if only a slight residual voltage is still present. For that reason, the voltage drop must also be taken into consideration during configuration.

Cable calculation

To ensure that the protective device shuts down safely in the event of a short circuit or overload current, it is a good idea to calculate the maximum usable cable length just to be on the safe side (Fig. 20 and 21).

The following data is necessary for the calculation:

R_{max}	Maximum total resistance
U	Nominal voltage
U_{CB}	Voltage drop for device circuit breaker
I_{CB}	Rated current for device circuit breaker
xI	Tripping factor in accordance with the current characteristic/nominal current multiplier
R_{Lmax}	Maximum cable resistance
R_{CB1A}	1 A internal resistance for device circuit breakers
L_{max}	Maximum cable length
A	Conductor cross section
ρ	Specific cable resistance Rho, (Cu 0.01786)

Values for sample calculation

U	= 24 V DC	
U_{CB}	= 0.14 V DC	
xI	= 15	> from the M1 characteristic curve
	= 2	> from the E characteristic curve
I_{CB}	= 1 A	
R_{CB1A}	= 1.1	> from table of typical internal resistances, Section 4.3
ρ	= 0.01786	> copper
A	= 1.5 mm ²	> assumed

$$R_{max} = \frac{U}{I_{CB} \cdot xI} = \frac{24 \text{ V}}{1 \text{ A} \cdot 15} = 1,6 \Omega$$

$$R_{Lmax} = R_{max} - R_{CB1A} = 1,6 \Omega - 1,1 \Omega = 0,5 \Omega$$

$$L_{max} = \frac{R_{Lmax} \cdot A}{\rho} = \frac{0,5 \Omega \cdot 1,5 \text{ mm}^2}{0,01786 \cdot \frac{\Omega \cdot \text{mm}^2}{\text{m}}} = 42 \text{ m}$$

Fig. 20: Calculation in three steps:

1. Total resistance of the circuit
2. Maximum cable resistance
3. Maximum cable length

$$R_{Lmax} = \frac{U - U_{CB}}{I_{CB} \cdot xI} = \frac{24 \text{ V} - 0,14 \text{ V}}{1 \text{ A} \cdot 2} = 11,93 \Omega$$

$$L_{max} = \frac{R_{Lmax} \cdot A}{\rho} = \frac{11,93 \Omega \cdot 1,5 \text{ mm}^2}{0,01786 \cdot \frac{\Omega \cdot \text{mm}^2}{\text{m}}} = 1001 \text{ m}$$

Fig. 21: Cable calculation for electronic circuit breakers

The value calculated is only theoretically possible. In practice, the voltage drop across the line must be taken into consideration.

5 Communication

The level of automation required is increasing year on year in many branches of industry. This brings with it a rising demand for communication and networking of components, including in the area of overcurrent protection.

Device circuit breakers connected to communication interfaces provide tremendous added value in the industry. The devices can be accessed remotely, making it possible to monitor and adjust the system process at any time from anywhere.

5.1 System transparency

Connecting to a communication interface gives you the option of energizing or de-energizing individual channels based on the process. However, the nominal current can also be conveniently adjusted. Processes can be depicted transparently right up to the load with the aid of a wide range of monitoring functions. This makes it possible to detect faults early and even prevent them. The ability

to access the system from anywhere in the world by connecting to the right interface can raise service and support to a completely new level. Every value, from the input voltage to the preset nominal current right up to the current actually flowing in the channel can be read out. Moreover, it is possible to remotely secure individual channels or the entire

circuit breaker against outside tampering. This can be done by locking in the nominal current setting or locking the entire device operation. IO-Link is one option for this kind of interface.

5.2 IO-Link

The first version of the IO-Link communication system was designed only to connect more intelligent sensors and actuators. The system was taken from the standard IEC 61131-9 from the description “Single-drop digital communication interface for small sensors and actuators (SDCI)”.

In the meantime, this communication protocol is also being incorporated into devices such as power supplies or

circuit breakers. One IO-Link master and one IO-Link device are required to set up IO-Link communication. The connection between these two devices is point-to-point.

One IO-Link master can have multiple IO-Link ports. One IO-Link device each can be connected per port (Fig. 22).

In its default setting, IO-Link uses 2 bytes to exchange cyclic process data between the master and the device.

The cycle time at this selected speed of 230 kBaud is 400 μ s. Larger frame types are also possible, enabling exchanges of cyclic process data up to 32 bytes. However, this always comes at the expense of the cycle time.

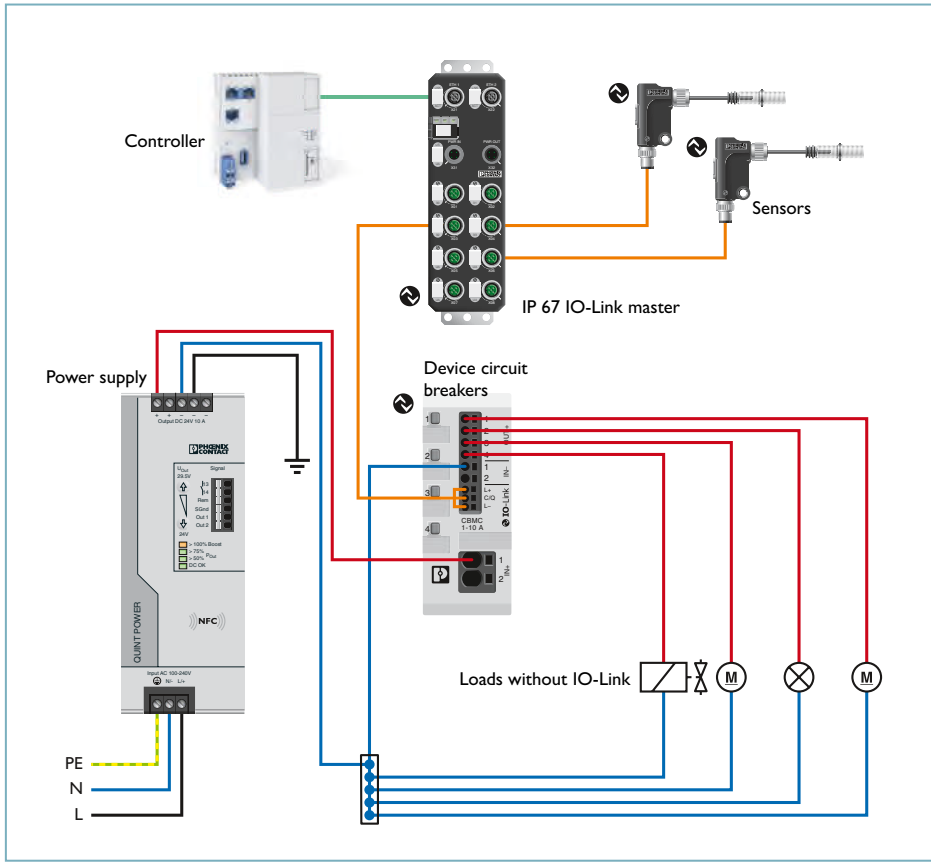

Fig. 22: IO-Link application example

IO device description

The IO device description, or IODD, is used during device installation and parameterization. A file of this type is available for every IO-Link device and is provided by every device manufacturer. In it, you will find the article or serial number, special device-specific information, and information about the manufacturer. Moreover, the IODD contains all of the functions of the device that can be adjusted or read.

Data storage

In addition to its basic functionality, the IO-Link communication system also offers a number of useful functions. These also include data storage. This function allows you to store the configuration of the IO-Link device in the master on the respective port being used. When replacing a device, e.g., due to a device failure, this stored information is then transferred to the new connected device. This makes device replacement more convenient and minimizes downtime.

6 Challenges in applications

The demands of normal system operation in no way represent a challenge when selecting device circuit breakers. What is more difficult is taking the starting behavior of the various loads into consideration. This is because the starting behavior frequently varies

greatly, often causing a multiple of the current to flow (Fig. 23 and 24). This situation must not result in a shutdown. This has to be taken into consideration both in the choice of device circuit breaker as well as the right power supply, the same as a potential fault. The power

supply must have sufficient reserve for this.

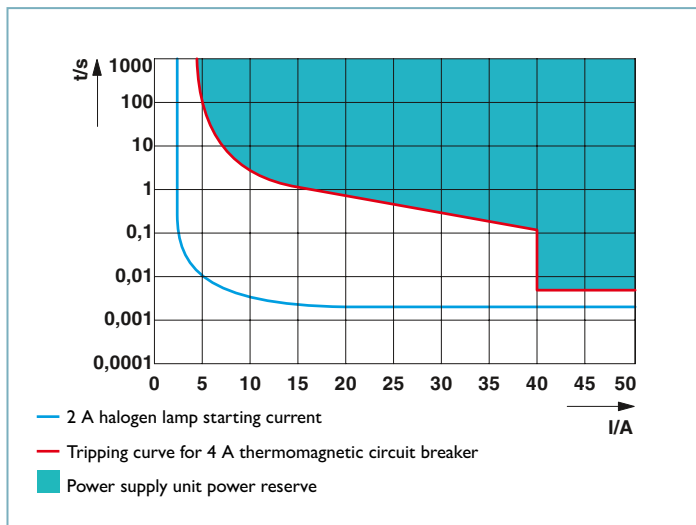

Fig. 23: A 4 A thermomagnetic circuit breaker indeed acts slowly enough to start the halogen lamp, but the power supply must also have a lot of reserve power ready.

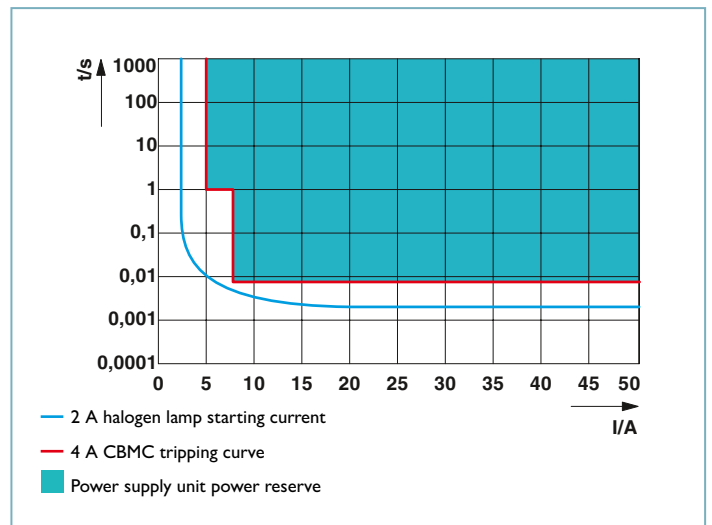
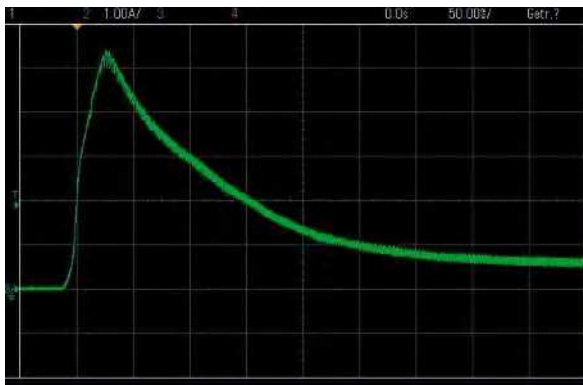

Fig. 24: Thanks to intelligent short-circuit and starting current detection, electronic circuit breakers can shut down more accurately under identical conditions. This means that a much smaller reserve is needed than with comparable thermomagnetic device circuit breakers (cf. Fig. 23).

DC motor startup behavior

Nominal current 500 mA
 Starting current/time $2 \times I_n = 1 \text{ A} / \text{approx. } 500 \text{ ms}$
 $8 \times I_n = 4 \text{ A} / \text{approx. } 50 \text{ ms}$



Fan startup behavior

Nominal current 500 mA
 Starting current/time $2 \times I_n = 1 \text{ A} / \text{approx. } 500 \text{ ms}$
 $3 \times I_n = 1.5 \text{ A} / \text{approx. } 100 \text{ ms}$

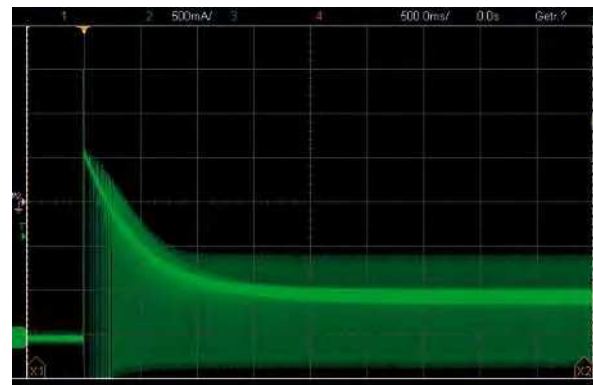

Small-scale controller startup behavior

Nominal current 100 mA
 Starting current/time $2 \times I_n = 200 \text{ mA}$ / approx. 180 ms
 $10 \times I_n = 2 \text{ A}$ / approx. 5 ms

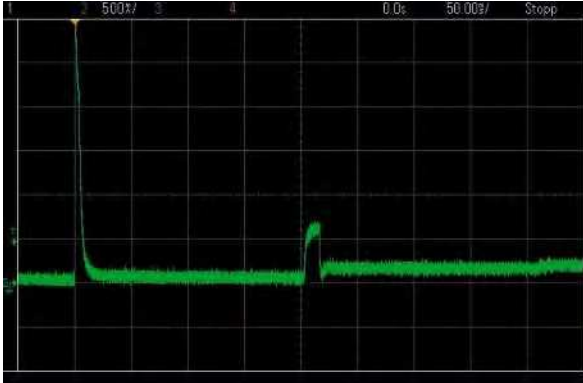

Halogen lamp startup behavior

Nominal current 2 A
 Starting current/time $2 \times I_n = 4 \text{ A}$ / approx. 25 ms
 $6 \times I_n = 12 \text{ A}$ / approx. 5 ms

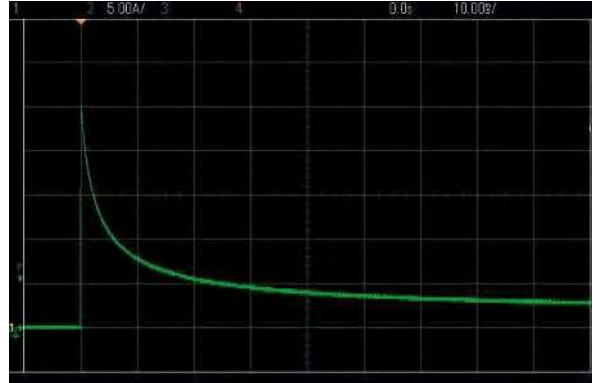

Load contactor startup behavior

Nominal current approx. 17 ms
 Starting current/time $2 \times I_n = 400 \text{ mA}$ / approx. 17 ms
 $30 \times I_n = 6 \text{ A}$ / approx. 10 ms

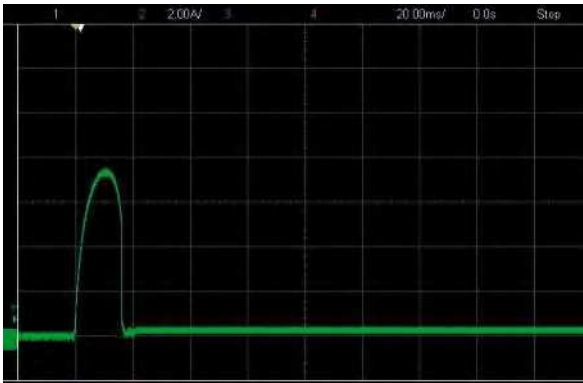

Temperature transducer startup behavior

Nominal current 100 mA
 Starting current/time $2 \times I_n = 200 \text{ mA}$ / approx. 2 ms
 $3 \times I_n = 300 \text{ mA}$ / approx. 1 ms

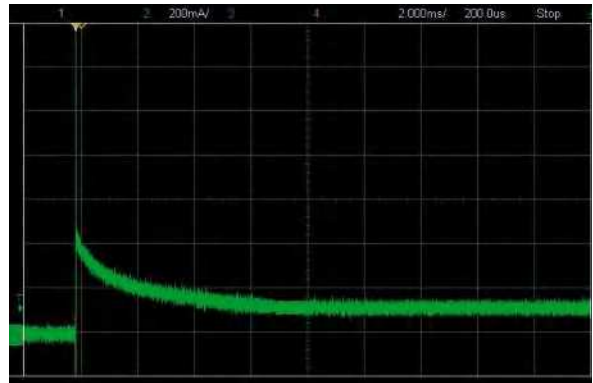

7 Standards and approvals

Different standards are important when using circuit breakers. In general, this is based on the different markets and industries where the products are being used. The IEC/EN standards are first and foremost in the European market. The American market specifies compliance with UL standards. For shipbuilding, for example, the pertinent shipping approvals are likewise required. These depend on the requirements of the customer.

7.1 European standards

The IEC/EN 60898 standard covers miniature circuit breakers for building installations and similar purposes. Conventional miniature circuit breakers have a high shutoff capacity of up to

5 to 6 kA. This shutoff capacity is not needed for switching devices, however. Device circuit breakers in accordance with IEC/EN 60934 are used in this case. Since there is no need for a particularly

high shutoff capacity, the design is significantly smaller, which brings a number of advantages along with it.

7.2 American standards

It is very important to many European machine building and systems manufacturers to use devices that have already been UL tested and listed in some way. Ideally, the devices used should be UL Listed or listed as components (UL Recognized). That makes any

potential export simpler, because the machine can be used in Europe and in the USA without problems. If the devices are only UL Recognized, they can be installed in a control cabinet or the like, which can then be submitted to be UL Listed as a complete system. On the other hand,

if a device is UL Listed, it can be used as a single component/device. UL Listing is accepted in Canada for the most part, so that the country-specific CSA approval is not absolutely necessary.

7.3 Approvals for shipping

The three following shipping approvals are the most important ones for the industry:

- DNV-GL
(Det Norske Veritas und Germanischer Lloyd)
- LR (Lloyd's Register of Shipping)
- ABS (American Bureau of Shipping)

The ambient conditions and influences on a shipping vessel are significantly harsher than in common machines and systems. For that reason, passing the required tests is very costly. Above all, impact, vibration, and EMC effects are tested at a very high level. This means that any device circuit breakers that are

approved for shipping can be used in most environments without a second thought.

7.4 EU declaration of conformity (CE marking)

An EU declaration of conformity is a manufacturer's way of certifying that the product it is placing on the market meets all of the applicable European directives and is in compliance with them. Electronic circuit breakers fall under the EMC Directive. This directive is the basis on which the declaration is being made. The EMC testing standards are applied in this case to test all of the criteria. If the product can be classified as safe and compliant, it receives CE marking.

Electronic circuit breakers are included among the equipment described in Directive 2014/30/EU (EMC Directive). Articles 2 and 3 in section 1 of this directive define the scope of application and definitions of terms.

An excerpt from 2014/30/EU: “‘apparatus’ means any finished appliance or combination thereof made available on the market as a single functional unit, intended for the end-user and liable to generate electromagnetic disturbance, or the performance of which is liable to be affected by such disturbance.”

Some important requirements of this directive are:

Equipment must be designed and manufactured in accordance with the state of the art so that it meets the following criteria:

- The electrical interference it causes does not reach levels which would prevent wireless and telecommunication devices or

other equipment from operating as intended.

- It is sufficiently resistant to the electromagnetic interference expected during proper operation to enable it to operate as intended without unreasonable impairment.

For the EU declaration of conformity, the fact that the devices meet the essential requirements of Directive 2014/30/EU and comply with the specific EMC standards must be verifiably documented by means of a conformity assessment procedure.

8 Safe system operation with products from Phoenix Contact

To achieve high system availability, it is important to consider more than just individual components. The entire system must be taken into consideration during planning. From the system input voltage to the load voltage, the components must be coordinated with each other. This is the only way to ensure availability. Phoenix Contact has just the right products to achieve this.



Surge protection

- Our customized surge protection solution provides ideal protection for industrial power supplies
- Protection status is transmitted to the control room via the floating remote indication contact
- Our pluggable surge protective devices can be easily tested and replaced in the event of an overload



Power supply

- Different functionalities, performance classes, and designs for different areas of application and different industries
- Our unique SFB technology and preventive function monitoring increase the application availability
- Easy system expansion thanks to Static Boost; difficult loads can be started using Dynamic Boost



Device circuit breakers

- The ideal device protection for any requirement thanks to our complete portfolio
- System status perfectly controlled thanks to the intelligent analysis and signaling of disturbances
- Easy startup, thanks to tool-free connection technology and intuitive operation

PTCB – Narrow electronic circuit breakers, universal at 6 mm

- Simple application setup, thanks to the ability to bridge to the CLIPLINE complete terminal block range
- More space in the control cabinet: narrowest protection with a width of just 6 mm
- Flexible use and less inventory due to adjustable current values on each device for a wide range of applications



CB E – Individually adaptable single-channel electronic circuit breakers

- Individually adjustable, thanks to protective plugs
- Large selection of protective plugs with fixed nominal current values for protection against unauthorized changes
- Active current limiting to improve the capacity of the upstream power supply



CBMC – Compact multi-channel electronic circuit breakers

- Easy device replacement without re-planning, thanks to compact design and options for individual adjustments
- Circuits can be adjusted without any tools by means of a single LED pushbutton
- Pre-configuration available – for device protection that meets the specific requirements of your system



CBM – Multi-channel electronic circuit breakers

- Easy configuration, thanks to the nominal current assistant
- Active current limiting to improve the capacity of the upstream power supply
- Adjustable in increments per channel: from 0.5 A to 10 A



9 Glossary

Active current limiting

Limiting of current flowing in any operating state to a specific manufacturer-specified maximum value. This applies both for fault currents as well as for starting currents.

Ambient temperature

Temperature of the air surrounding the equipment.

Auxiliary contact

Contact in the auxiliary circuit that is used as a remote indication contact.

Backup fuse

Integrated, additional fuse element that protects the device circuit breaker in the unlikely event that the electronics fail.

Changeover contact

Signal contact with three connections that provides N/C contact and N/O contact functions.

Clearance

This is the shortest distance between two conductive parts.

Conditional short-circuit current rating

Conditional short-circuit current rating I_{nc} describes the maximum current that a circuit breaker or protective device can interrupt, where the operation of the circuit breaker need not be preserved for further use. The conditional short-circuit current rating must be larger than the maximum possible short-circuit current in the circuit. This is understood as the prospective short-circuit current that would be flowing in the circuit over the shortest path without any protective device.

Connection method

Specification for conductor connection technology, e.g., a screw terminal block or screw-less push-in connection.

Creepage distance

Shortest distance along the surface of an insulation material between two conductive parts.

Current limiting

See Active current limiting

Device circuit breakers

Circuit breakers that protect from possible failures resulting from short circuit or overload. They are specially designed to protect devices and actuators in technical systems and machines.

Electrical isolation

Additional physical interruption of the primary load current across an actual clearance by self-opening contacts.

Electronic interlock

Locking mechanism to prevent an accidental adjustment to the nominal current of each channel once it is set.

Fuses

Fuses open a circuit and shut off the current if a permitted current value is exceeded over a long period of time.

Main contact

Contact in the main circuit that conducts the current when closed.

Miniature circuit breakers

These are used to protect cables from damage that could occur as a consequence of overload or short circuit.

MOSFET

Metal oxide semiconductor field-effect transistor in an electronic circuit breaker.

MTBF

(Mean Time Between Failures)
The expected operational period between two consecutive failures.

Number of channels

There are single-channel and multi-channel device circuit breakers. In multi-channel circuit breakers, the individual channels are independent of each other and protect different paths.

Number of positions

The number of positions indicates how many current paths are being protected simultaneously and shut down by multiple positions in the event of a fault. The individual current paths are coupled together and must be shut down together in the event of a fault.

N/C contact

Floating auxiliary contact. Opens if the main contact is closed.

N/O contact

Floating auxiliary contact. Closes if the main contact is closed.

Operating characteristic curves

Characteristic curves that describe the behavior of a device circuit breaker below specific current and voltage values.

Overcurrent shutdown

Conventional circuit breakers shut off the overcurrent in the event of a fault within the tripping range of their time-current characteristic curve.

Overload current

Overload current is current in excess of the nominal current and must not be allowed to continue to flow.

Power dissipation in nominal operation

No-load power dissipation describes the closed-circuit current of the circuit breaker that is needed for auxiliary power consumption. Maximum power dissipation in nominal operation refers to the power output that occurs in all circuits (main circuit, control circuit, signaling circuit) while operating under the highest rated current and highest rated voltage, plus the power dissipation for auxiliary power consumption.

Rated current

Rated current I_N in the context of circuit breakers is understood as the current that may flow continuously under the conditions established by the manufacturer and at which the circuit breaker must not trip. The conditions include the nominal voltage, the ambient temperature, and the installation position, for example.

Rated short-circuit switching capacity

The rated short-circuit switching capacity I_{cn} is the maximum current that a circuit breaker should switch on, conduct while open, and shut down under specified conditions. In this case, the rule applies that the twice repeated switching on to a short circuit must be also successfully managed by the circuit breaker.

Rated values

Values for which a piece of equipment is rated, e.g., rated current, voltage, frequency.

Rated voltage

Rated voltage U_N in the context of circuit breakers is understood as the voltage value to which the operating and performance characteristics refer.

SFB characteristic curve in thermomagnetic circuit breakers (SFB, Selective Fuse Breaking)

Device circuit breakers that work on the basis of this characteristic curve trip more easily in the event of a short circuit. The SFB tripping characteristic falls between the M1 and F1 characteristic curve.

SFB technology in power supplies (Selective Fuse Breaking)

Power supplies that operate based on this technology provide a high current reserve in the event of a short circuit. Even for long cable paths, the safety equipment is supplied with the required breaking current. Any unaffected system parts also connected to this power supply continue to be supplied with power.

Short-circuit current

This current arises between an incorrect low-resistance connection between two points, which usually have different potentials.

Short-circuit detection

Phoenix Contact electronic circuit breakers are equipped with intelligent short-circuit detection. This enables them to start loads with high starting currents even in the short-circuit tripping range while also detecting even small short-circuit currents as such and shutting them off within a few milliseconds.

Short-circuit tripping range

Thermomagnetic and electronic circuit breakers have a short-circuit tripping range that, depending on the type, corresponds to 1.5 to 15 times the nominal current value. Shutdown in this case takes place within a few milliseconds.

Switching cycles

Sequence of actuations from one position to another and back.

Temporary dielectric strength

Maximum temporary voltage value that can be tolerated without causing any insulation damage under specified conditions.

Trip-free mechanism

Tripping of a device circuit breaker that does not involve any change in the switch position of the operating lever.

Tripping characteristics

Tripping characteristics indicate the tripping behavior of a device circuit breaker. The switching time and amperage at which a circuit breaker trips are shown in a diagram.

Tripping range

The tripping behavior cannot be defined using a single precise characteristic curve. The internal components are subject to certain tolerances. For that reason, a tripping range within which the device circuit breaker operates is specified. Electronic circuit breakers also have tolerances, but they fail at significantly lower rates and therefore provide more accurate protection.

Type of actuation

Describes how a device circuit breaker is operated or reset. Versions are available with automatic reset or versions with manual actuation. These are equipped with an operating lever for regular or irregular switching operations.

80% early warning

The early warning signals that 80% of the preset nominal current has been reached for each channel.

In dialog with customers and partners worldwide

Phoenix Contact is a globally present, Germany-based market leader. Our group is synonym for future-oriented components, systems, and solutions in the fields of electrical engineering, electronics, and automation. A global network across more than 100 countries, and 16,500 employees ensure a close proximity to our customers, which we believe is particularly important.

The wide variety of our innovative products makes it easy for our customers to find future-oriented solutions for different applications and industries. We especially focus on the fields of energy, infrastructure, process and factory automation.



You will find our complete product range at:
phoenixcontact.com

PHOENIX CONTACT GmbH & Co. KG
Flachmarktstraße 8
32825 Blomberg, Germany
Phone: +49 52 35 3-00
Fax: +49 52 35 3-4 12 00
E-mail: info@phoenixcontact.com
phoenixcontact.com